

Product Parts

1 - Hardware

- a - Top Curved Poles (x2)
- b - Bottom Back Curved Poles (x2)
- c - Curved Side Poles (x2)
- d - Straight Side Poles (x2)
- e - Literature Rack (x2)
- f - Horizontal Poles (x3)
- g - Bottom Front Curved Poles (x2)
- h - Tablet Bracket
- i - Tablet Knobs (x2)
- j - Hex Wrench
- k - Security cable

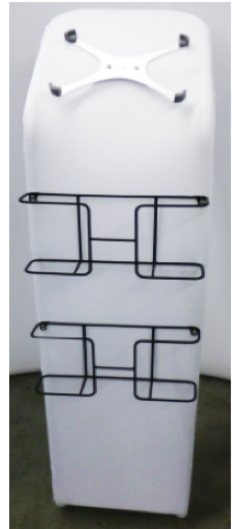
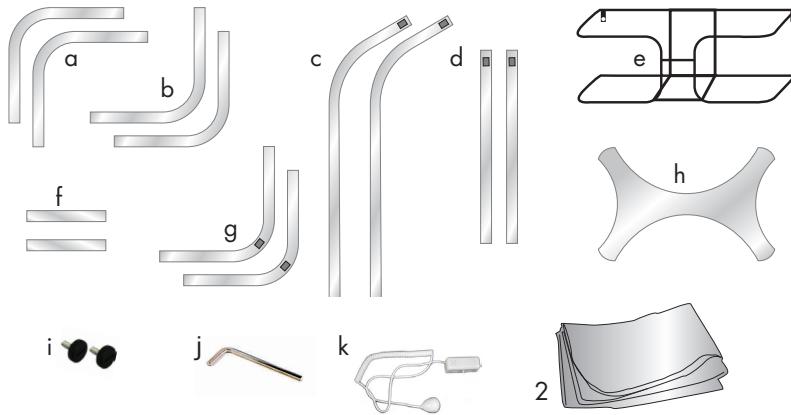

2 - Graphic

Hardware Assembly

Step 1

Open all parts to the hardware and assemble the parts using the diagram illustrated to the right.

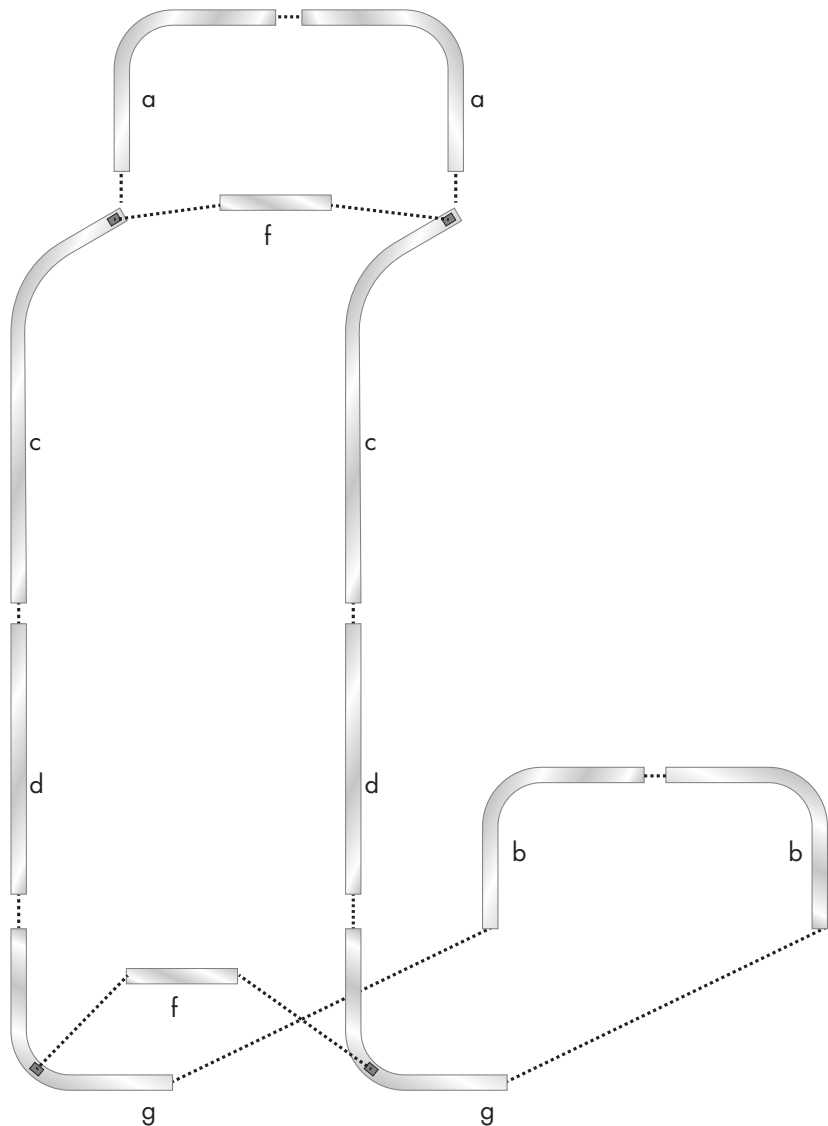
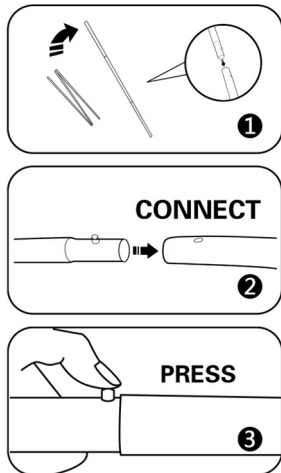

Graphic Setup

Step 1

Set the assembled hardware on a clean surface. Locate the bottom of the graphic (zippered end) and slide it over the top of the hardware and continue to slide down over hardware.

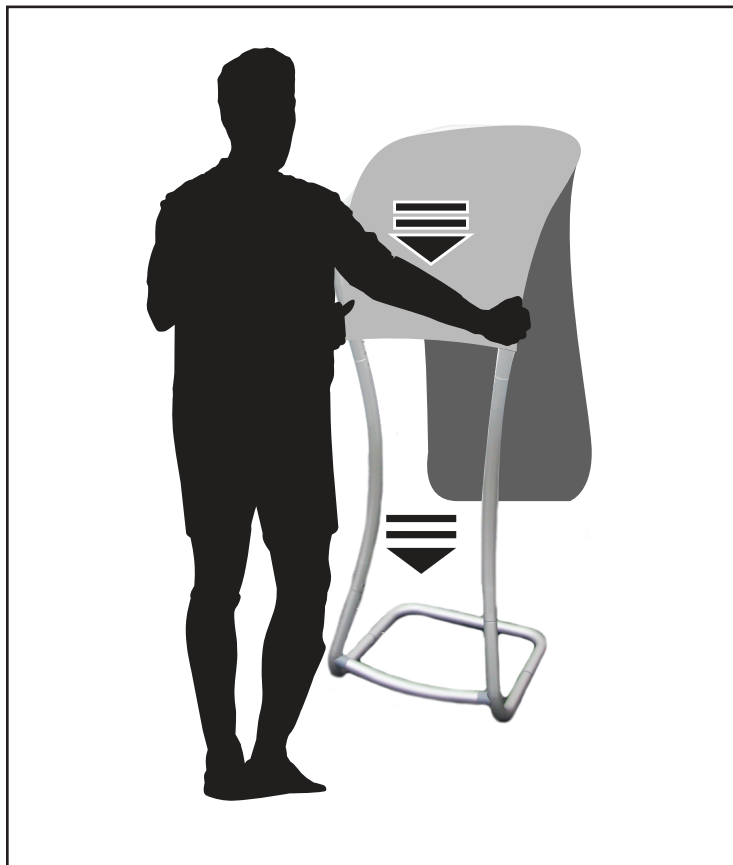

NOTE:

The graphic is designed to fit the hardware precisely, as a result the graphic may appear to be too tight during the installation process (this is normal).

Step 2

Zip the Graphic Closed on the bottom.

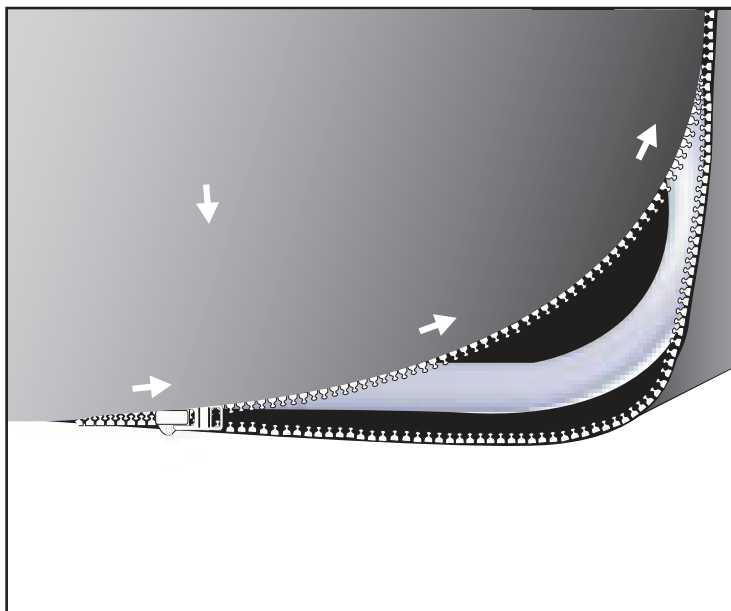

Step 3

Attach the Literature Racks (e) to the attached screws on the verticle poles. Attach the Tablet Bracket (h) using the Screws (i) provided.

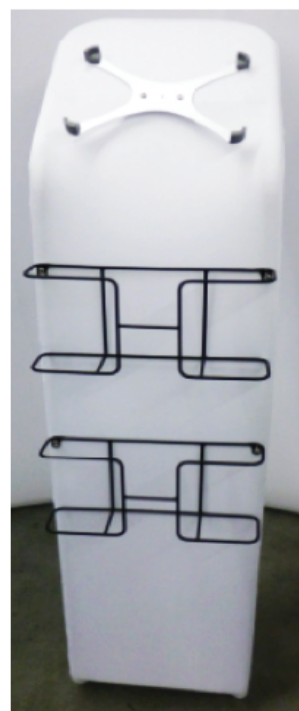
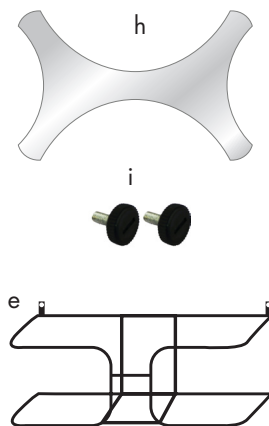

Storage

Store in a cool dry location.

Care

Machine wash cold, gentle cycle. Air Dry Only